

EK-Loop Modulus Hard Tube Bending Tool – 12/14/16

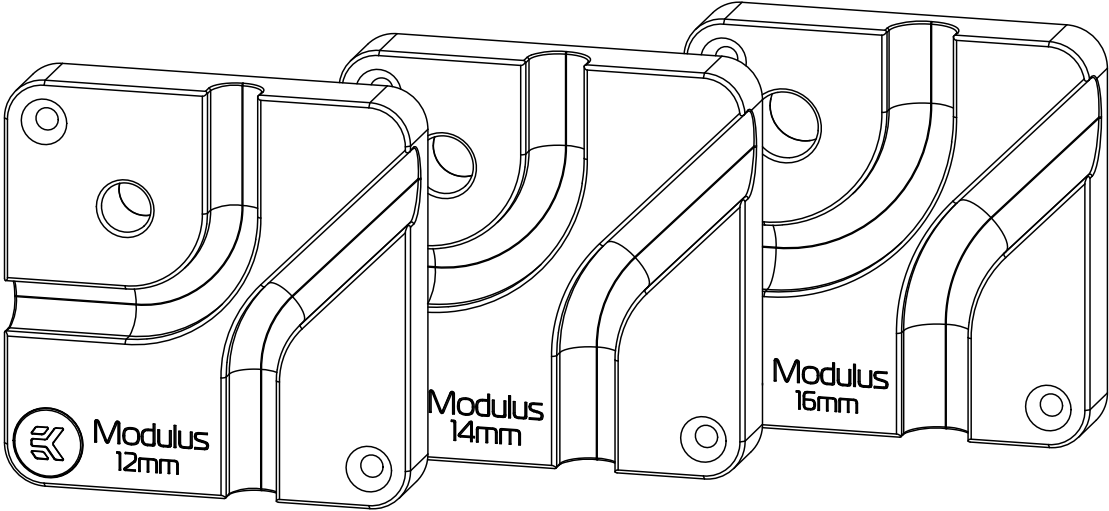

This product is intended for installation only by expert users. Please consult with a qualified technician for installation. Improper installation may result in damage to your equipment. EK Water Blocks assumes no liability whatsoever, expressed or implied, for the use of these products, nor their installation. The following instructions are subject to change without notice. Please visit our web site at for updates. Before installation of this product please read important notice, disclosure and warranty conditions printed on the back of the box or our home page.

TABLE OF CONTENT

BENDING TUBES	4
REQUIRED TOOLS	6
SUPPORT AND SERVICE	7
SOCIAL MEDIA	7

BENDING TUBES

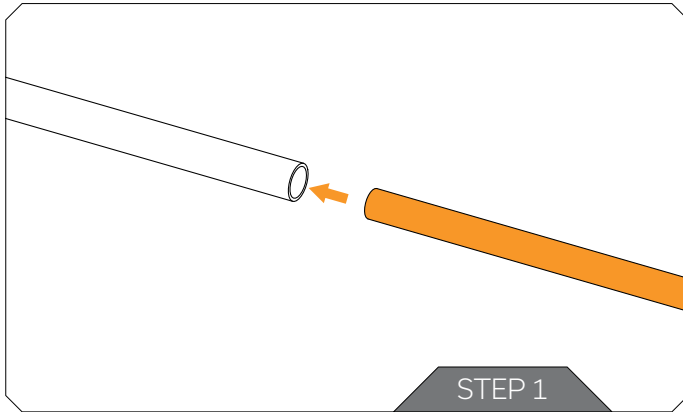

STEP 1:

First you need to put silicon insert inside your ACRYLIC/PETG tube. You can use soap and a bit of water on silicon rod for easier installation.

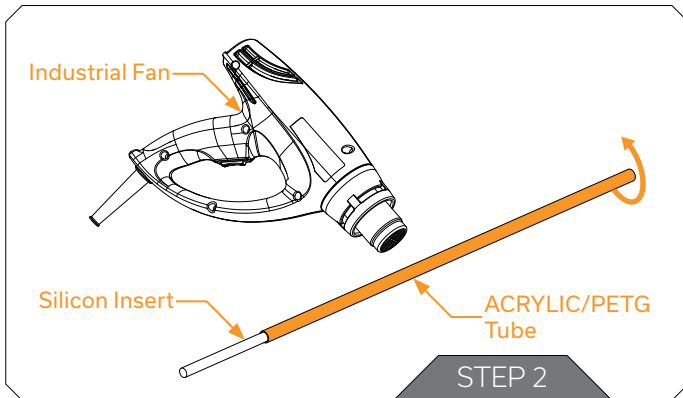

STEP 2:

Use industrial fan to heat up the ACRYLIC/PETG tube. You need to rotate the tube while heating. You will notice that the tube is heated enough when it starts to deflect under its own weight.

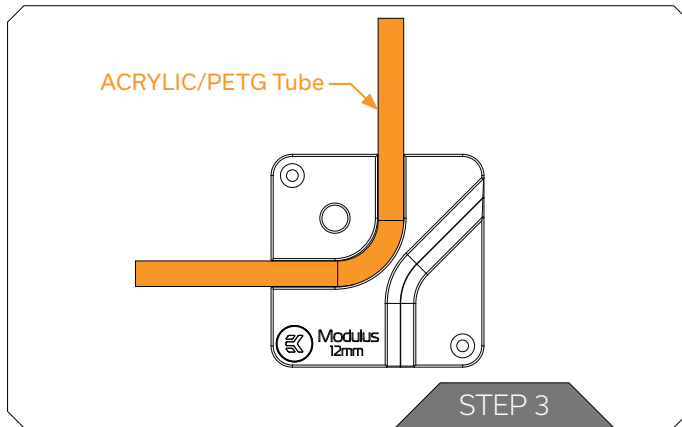

STEP 3

Bend the tube around EK-Loop Modulus hard tube Bending tool. When you force the tube into its final position leave hold it for about 15 seconds so that it hardens a bit. It is recommended to pull the silicone rod out of the tubing when it's still warm.

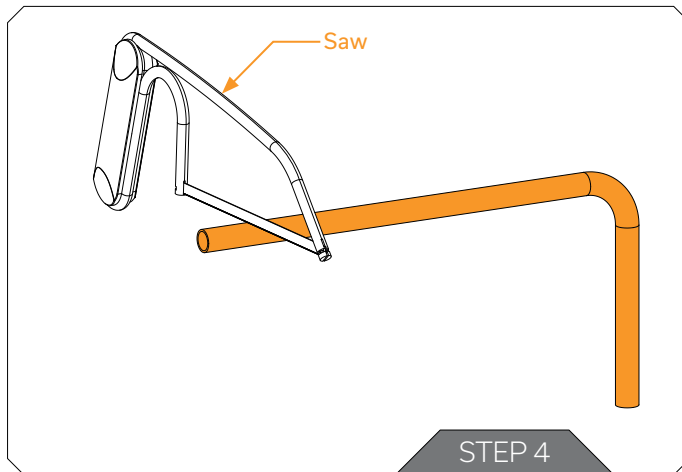

STEP 4

You need to cut the tube to desired length. Use a fine hacksaw or equivalent.

STEP 5

When finished you can use the tube reamer or sandpaper to chamfer the edges for easier installation into the fittings.

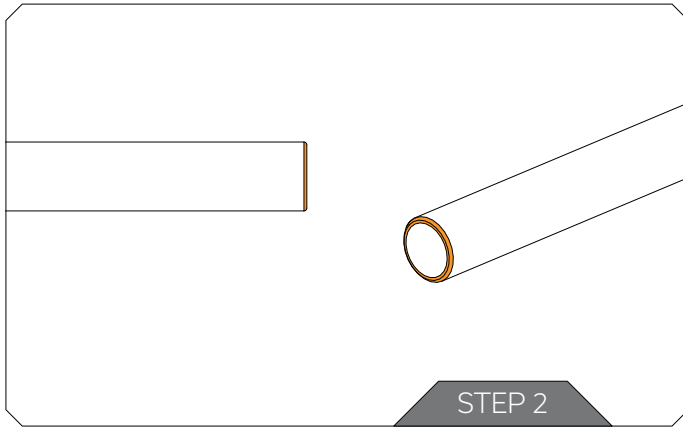

REQUIRED TOOLS

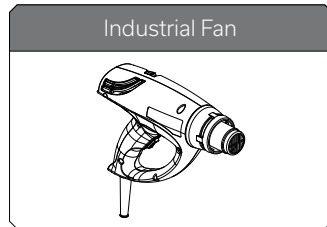
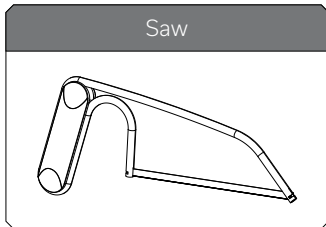

SUPPORT AND SERVICE

For assistance please contact:

<http://support.ekwb.com/>

EKWB d.o.o.
Pod lipami 18
1218 Komenda
Slovenia - EU

SOCIAL MEDIA

 EKWaterBlocks

 @EKWaterBlocks

 ekwaterblocks

 EKWBofficial

 ekwaterblocks

